

Product data sheet

Characteristics

XVUC45

Illuminated LED unit for modular tower lights, orange, Ø60, blinking, IP65, 24 V AC/DC

Product availability : Stock - Normally stocked in distribution facility



Main

Range of product	Harmony XVU
Product or component type	Modular tower light
Beacon or indicator bank unit type	LED unit
Mounting diameter	2.36 in (60 mm)
Component name	XVU
Light source	LED, orange
Device application	Automotive Machine tools Packaging machine

Complementary

Signalling type	Blinking
Assembly style	Up to 4 units with buzzer Customer assembly, up to 5 units
Material	PC (polycarbonate) V-2 conforming to UL 94 PC (polycarbonate) V-0 UL 94
[Us] rated supply voltage	24 V AC/DC
Maximum power dissipation in W	0.9 W
Signalling type	Blinking
Length	1.97 in (50 mm)
Net Weight	0.14 lb(US) (0.064 kg)

Environment

Product certifications	UL CE CSA
------------------------	-----------------

* Price is "List Price" and may be subject to a trade discount – check with your local distributor or retailer for actual price.

RoHS

Ambient air temperature for storage	-40...158 °F (-40...70 °C)
IP degree of protection	IP65
Ambient air temperature for operation	-13...122 °F (-25...50 °C)
Vibration resistance	2 gn

Ordering and shipping details

Category	22618 - XVU TOWER LIGHTS
Discount Schedule	XV
GTIN	00785901086277
Nbr. of units in pkg.	1
Package weight(Lbs)	0.32 lb(US) (0.15 kg)
Returnability	Yes
Country of origin	ID

Packing Units

Unit Type of Package 1	PCE
Package 1 Height	3.54 in (9 cm)
Package 1 width	3.62 in (9.2 cm)
Package 1 Length	5.16 in (13.1 cm)
Package 2 Weight	8.99 lb(US) (4.079 kg)

Offer Sustainability

Sustainable offer status	Green Premium product
California proposition 65	WARNING: This product can expose you to chemicals including: Lead and lead compounds, which is known to the State of California to cause cancer and birth defects or other reproductive harm. For more information go to www.P65Warnings.ca.gov
REACH Regulation	REACH Declaration
EU RoHS Directive	Pro-active compliance (Product out of EU RoHS legal scope) EU RoHS Declaration
Mercury free	Yes
RoHS exemption information	Yes
China RoHS Regulation	China RoHS declaration
Environmental Disclosure	Product Environmental Profile
Circularity Profile	End of Life Information

Illuminated LED Unit

Dimensions

$\frac{\text{mm}}{\text{in.}}$

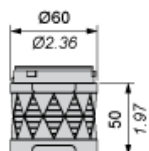

Modular Tower Lights Mounting

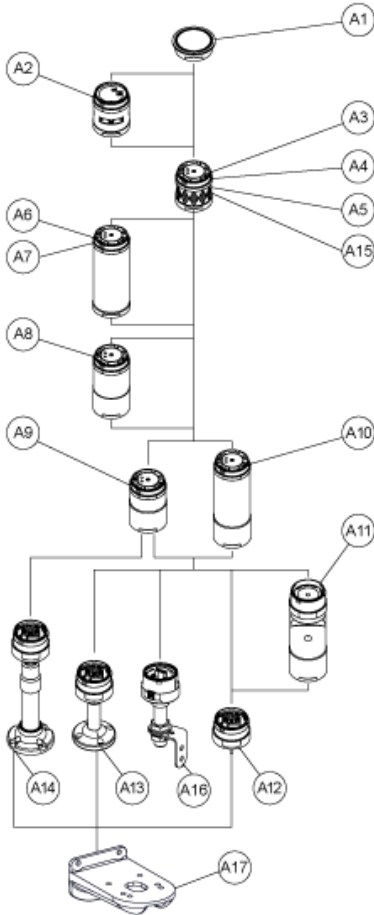

Drawing	Part number	Part name
A1	-	Top cover
	-	Top cover (Silver)
A2	XVUC9S	Buzzer unit
	XVUC9SQ	Buzzer unit (Silver)
A3	XVUC23	Green LED unit
	XVUC24	Red LED unit
	XVUC25	Orange LED unit
	XVUC26	Blue LED unit
	XVUC27	White LED unit
	XVUC28	Yellow LED unit
A4	XVUC29	Multi-LED unit
A5	XVUC29P	Multi-LED unit, Pulse signal
A6	XVUC9V	Sound unit
A7	XVUC9VP	Sound unit, Pulse signal

Drawing	Part number	Part name
A8	XVUC020	Extender
	XVUC020Q	Extender (Silver)
A9	XVUC21B	DC body
	XVUC21BQ	DC body (Silver)
A10	XVUC21M	AC body NPN
	XVUC21MP	AC body PNP
	XVUC21MQP	AC body PNP (Silver)
A11	XVUZ06	Flexible option
A12	XVUZ01	Fixing Unit - Direct mounting (3 pins)
	XVUZ01Q	Fixing Unit - Direct mounting (Silver,3 pins)
	XVUZ03	Fixing Unit - Direct mounting (2 pins)
	XVUZ04	Fixing Unit - Direct mounting (4 pins)
A13	XVUZ02	Fixing Unit - Plate with Pole (100 mm)
	XVUZ02Q	Fixing Unit - Plate with Pole (100 mm, Silver)
	XVUZ400	Fixing Unit - Plate with Pole (400 mm)
	XVUZ800	Fixing Unit - Plate with Pole (800 mm)
A14	XVUZ05	Fixing Unit - Plate with adjustment pole (100-385 mm)
A15	XVUC43	Green LED unit, Flash
	XVUC44	Red LED unit, Flash
	XVUC45	Orange LED unit, Flash
	XVUC46	Blue LED unit, Flash
	XVUC47	White LED unit, Flash
	XVUC48	Yellow LED unit, Flash
A16	XVUZ100T	Fixing Unit - Metal bracket with pole (100 mm)
	XVUZ250T	Fixing Unit - Metal bracket with pole(250 mm)
	XVUZ400T	Fixing Unit - Metal bracket with pole (400 mm)
A17	XVUZ12	Fixing plate for use on vertical support - black

Illuminated Units, Multi-LED and Audible Units Wiring

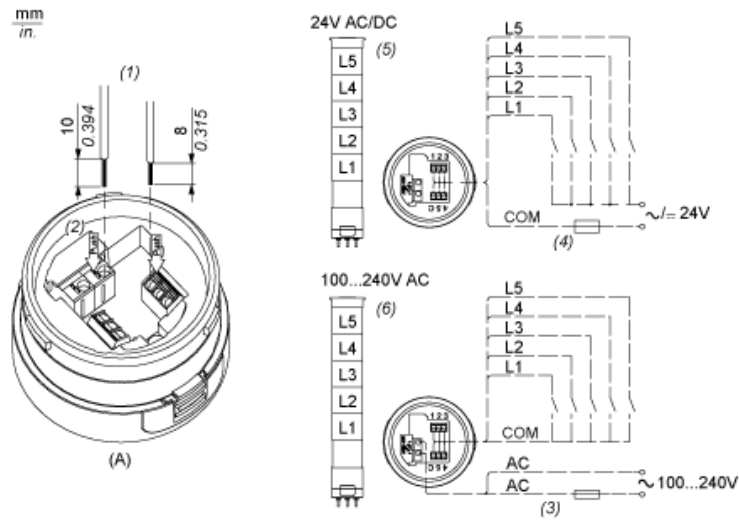

- (A) Fixing Unit
 - (1) Dimensions of Wiring size
 - (2) Push-in Wire Connectors
 - (3) Fuse : 2A ,250V
 - (4) Fuse : 0.5A ,125V
 - (5) Modular Tower Lights 24V AC/DC
 - (6) Modular Tower Lights 100...240V AC
- L1 to L5 : Illuminated LED Units